

±165 (6.5")

approx 11.5kg (25lb)

- PENDANTS: six
- MOUNTING: black rubberized stainless steel canopy 160mm (6.3") in diameter x 40mm (1.6") deep
- LAMPING: 1.5w LED (9w total draw)
- EXTENDER: available in 250mm (9.8") / 500mm (19.7") / 1200mm (47.2"). Up to 2.5m (98") drop.
- MATERIALS: blown glass, matte black rubberized stainless steel armature, electrical components, matte black canopy
- WEIGHT: approximately 11.5kg (25lb)
- POWER SUPPLIES: integral

#### DESCRIPTION

A steel armature system in a soft-touch matte black finish allows pre-composed branches to be easily connected to a series of hubs during installation.

Individual 28 pendants result from a complex glass blowing technique whereby air pressure is intermittently introduced into and then removed from a glass matrix which is intermittently heated and then rapidly cooled. The result is a distorted spherical shape with a composed collection of imploded inner shapes, one of which acts as a shade for the light source.

Standard 28s are made with clear glass exterior spheres and milk white interior lamp holder cavities. 28s are possible with infinite versatility in colour compositions, sizes and shapes.

#### NOTES

- + Purchase replacement lamps online at [www.bocci.ca/shop/bulbs](http://www.bocci.ca/shop/bulbs)
- + Power supplies can be mounted remotely in an easily accessible and hidden location for ease of long-term maintenance.

CAD Patent # 134238  
US Patent # D687,740  
EU Patent # 001695834-001 to 004

Made in Vancouver, Canada

Vancouver  
sales@bocci.ca  
www.bocci.ca

Berlin  
europe@bocci.ca  
www.bocci.ca

ARMATURE

# 28.6a

Design by Omer Arbel  
PRODUCT INSTALLATION INSTRUCTIONS

© 2019, Bocci Design and Manufacturing Inc. All rights reserved. Any inquiries should be directed to: [info@bocci.ca](mailto:info@bocci.ca)

# BOCCI

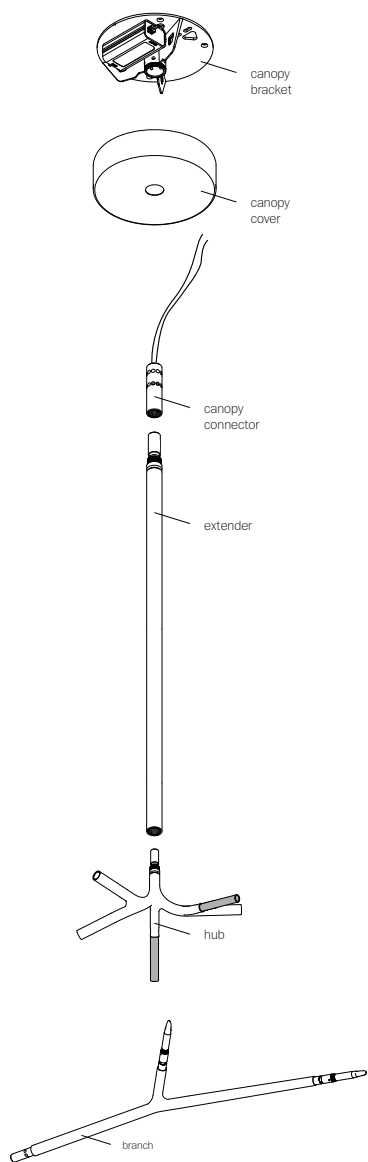

1

Feed the canopy connector wires through the slots on the canopy bracket.

Attach canopy connector to the canopy bracket with a single screw, just to hold it in place.

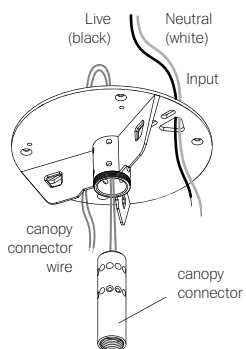

2

Measure and mark fixture location on the ceiling. Open the ceiling in this location to create an adequate structural support for the canopy bracket and remote mounted power supplies. Wood backing at least 2" (51mm) thick is recommended.

Feed the Live and Neutral wires through the slots on the canopy bracket.

Anchor the canopy bracket to the wood/support structure and ensure that the bracket fasteners (provided) are engaged to a depth of at least 25mm (1").

Note: If you are using different screws please make sure they are able to support 36kg/80lb in traction and are engaged to at least 25mm (1") in the substrate.

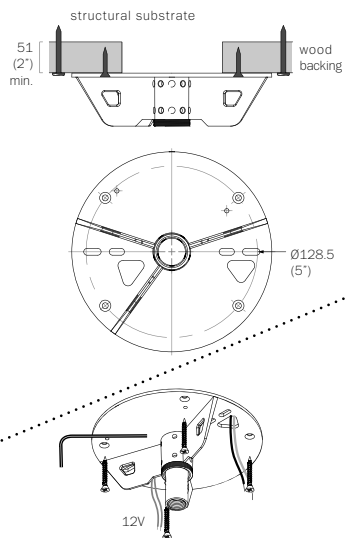

3

Thread the hub to the extender and secure with set screw (provided).

Do not remove protective material before completion.

Note: If the system does not require an extender, then thread the hub onto the canopy connector and secure with set screw.

Pass the canopy cover through the extender (or the hub if no extender is used).

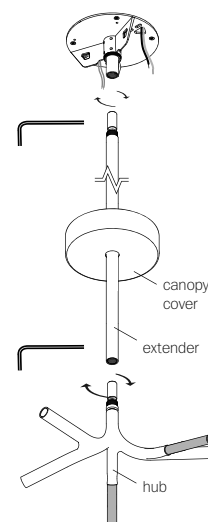

4

Check the orientation of the fixture.

Please reference the drawing on the first page of the spec sheet.

Loosen the screw on the canopy connector and rotate to the desired position.

There are two rows of screws around the circumference of the bracket (5 screws in each row).

i. Tighten row A (refer to picture). These must be tightened evenly so that all set screws are equally engaged. Tightening one side more than another will lead to an off-center result.

ii. Tighten row B in the same manner (refer to picture).

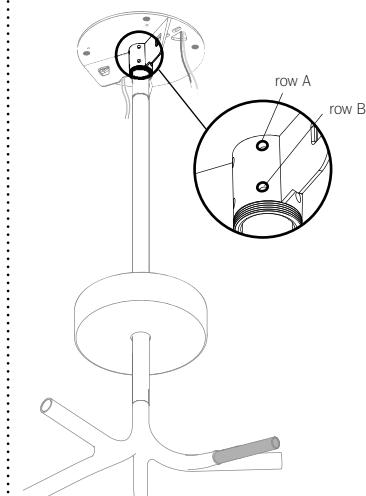

ARMATURE

28.6a

Design by Omer Arbel  
PRODUCT INSTALLATION INSTRUCTIONS

© 2019, Bocci Design and Manufacturing Inc. All rights reserved. Any inquiries should be directed to: info@bocci.ca

**BOCCI**

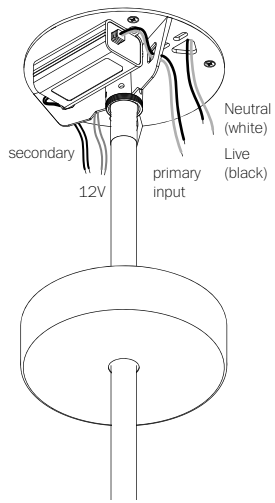

8

- i. Attach the driver to the canopy bracket.
- ii. Feed the AC input and DC output wires through the slots on the canopy bracket.
- iii. Connect the canopy connector wires to the low voltage secondary driver wires.
- iv. Connect supply wires to primary input wires of driver. Ensure 'Live' & 'Neutral' wires are respected. (Ensure that line voltage is not active during this part of the installation).
- v. Thread the canopy cover onto the canopy bracket and turn power to fixture on.

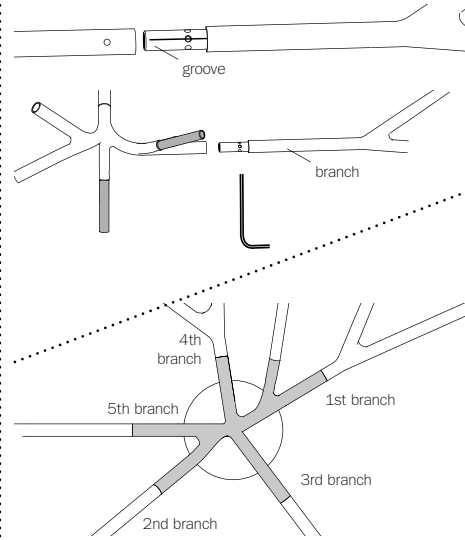

9

- Begin assembling the branches.
- Position each branch with the groove facing upwards (refer to picture) and align with the screw hole. Tighten the branch in place with a set screw (provided). Attach 2nd branch (if applicable) opposite to the first branch so the system is balanced during installation. Repeat steps as necessary.

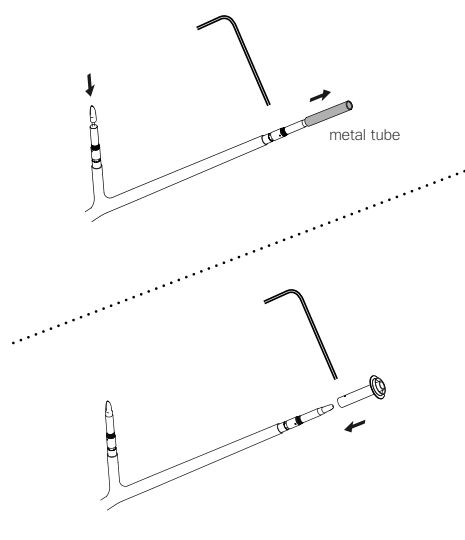

10

- Remove the metal tubes at the end of each branch by unscrewing the set screw. Insert provided LED into socket. Check that each lamp is working properly as you go along by keeping the power on.
- Insert pendant holder onto socket and secure with set screws (provided).

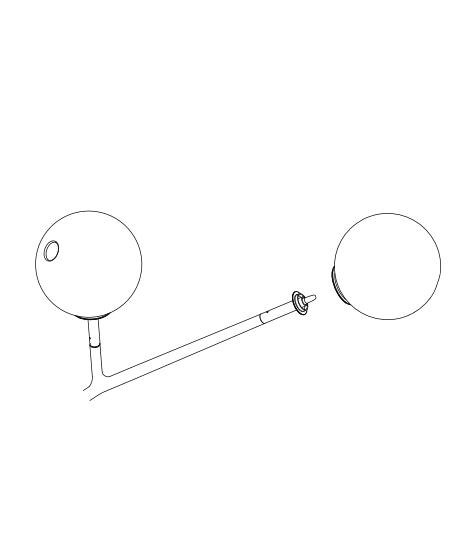

11

- Thread the pendant onto the pendant holder and secure with set screw.
- Be sure to carefully place the pendant so as not to damage the LED during installation.

For additional assistance, please contact Bocci:

Vancouver  
sales@bocci.ca  
www.bocci.ca

Berlin  
europe@bocci.ca  
www.bocci.ca

CAD Patent # 134238  
US Patent # D687,740  
EU Patent # 001695834-001 to 004

Made in Vancouver, Canada